

Technical Article

Crusher Bearings:

Knowing the Basics Leads to Better Care



by Brian Berg and Fabiana Maggico, Manager - Upstream Marketing at The Timken Company

Table of Contents:

Compression Crushers	2
Jaw Crushers	2
Cone Crushers	2
Impact Crushers	3
Better Bearing Care	3
Lubrication	3
Bearing Fit on Shaft and in Housing	4
Damage Analysis	4
Training	5

Crusher Bearings:

Knowing the Basics Leads to Better Care

Abstract

High shock loads and severe contamination make rock and aggregate crushers among the toughest applications for precision components – particularly roller bearings. The harsh environments in which crushers operate present a big challenge to bearing performance and present a constant threat to long, reliable equipment life. Keeping machine availability high and cost-of-ownership low in these conditions requires a commitment to proper care, including routine inspection and re-lubrication of roller bearings in compression and impact crushers. Knowing the common types of bearings used in crushing equipment can help operators and maintenance personnel understand how different designs impact performance.



Figure 1:
Jaw crusher.

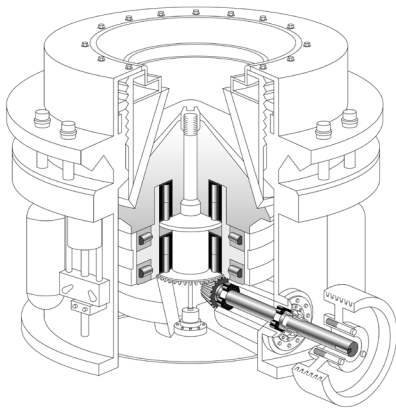

Figure 2:
Cylindrical, tapered, thrust and plain bearings are all commonly found in a cone crusher.

Compression Crushers

In compression crushers, high start-up torque, shock loads and vibration demand high-performing anti-friction bearings that can operate reliably with minimal heat generation.

Jaw Crushers

Most operations prefer jaw crushers for primary crushing. A large feed opening allows these crushers to receive larger-sized material than most other types of machines. Bearing speeds and loads are generally moderate, but, on occasion, the load spikes as uncrushable material passes through the chamber.

In a typical jaw crusher, two outer bearings located on either side of the main frame support an eccentric shaft, while two inner bearings support a movable jaw. These are commonly known as “Pitman” bearings. The reciprocating motion of the shaft moves the Pitman against a second, stationary jaw. As material reaches the bottom of the chamber, it fractures as it becomes wedged between the jaws. Jaw crushers typically utilize spherical roller bearings, chosen for their ability to manage high radial loads and the presence of misalignment. Spherical roller bearings self-align and thus better compensate for shaft deflections and seat misalignment.

Cone Crushers

Cone or gyratory crushers use a variety of specialized bearings specifically designed for each model. Like jaw crushers, these machines – common in primary, secondary and tertiary crushing circuits – also operate at moderate speeds under heavy loads and experience significant load spikes. In a standard cone crusher, the main shaft is housed in a frame attached to a mantle. A pinion (counter) shaft assembly drives a bevel gear that rotates the cone. As material presses against the bowl liner by the mantle or cone, it is crushed into smaller pieces that fall through to the bottom.

Most cone crushers have two radial bearings and two axial bearings. The radial bearings are most commonly special cylindrical roller bearing designs, featuring two rollers per pocket with differing roller lengths. The axial bearings typically combine a tapered thrust bearing and cylindrical thrust bearing.

Impact Crushers

Secondary crushing circuits commonly use hammer mills and vertical and horizontal impact crushers and experience high-rotational speeds and variable loading conditions. They tend to use spherical roller bearings for flexibility and to accommodate misalignment.

In hammer mills and horizontal crushers, spherical roller bearings in solid or split pillow block housings generally support the impactor shaft on both sides. Spherical roller bearings are a common choice because of their ability to handle the combination of radial loads and shaft misalignment that occurs during crushing. Pillow blocks protect bearings from contaminants and provide support for the bearing during the crusher operation. Pillow block bearings are often lubricated. The grease provides lubrication for the bearing and a layer of protection for external contamination.

Better Bearing Care

If operators must frequently replace damaged bearings or suspect they simply are not getting the life out of their bearings that they expect, a few simple steps to follow and options to explore can improve the performance and uptime of machines in crushing circuits.

Lubrication

Poor lubrication is a leading cause of bearing failure in most industrial applications, including crushers. A proper re-lubrication schedule is critical to maintain appropriate bearing operating temperatures, which affect lubricant viscosity and life. As a general rule, a lubricant should maintain a minimum viscosity of 105 SUS (21.8 cSt) at the bearing operating temperature.

In most cases, the Original OEM collaborates with the bearing manufacturer to develop a recommended re-lubrication schedule. Operators and maintainers should follow the OEM re-lubrication schedule to help maximize the bearing life. They also should take further care not to over lubricate bearings. In grease lubrication systems, over-greasing can lead to excessive heat generation from lubricant churning. The excessive heat breaks down the lubrication and can cause premature bearing failure. Mixing different greases or other lubricants should also be avoided, as this can result in breakdowns and may cause premature failure. To ensure that re-lubrication practices remain on point, one call to a qualified expert can save hours – or days – of unscheduled downtime.

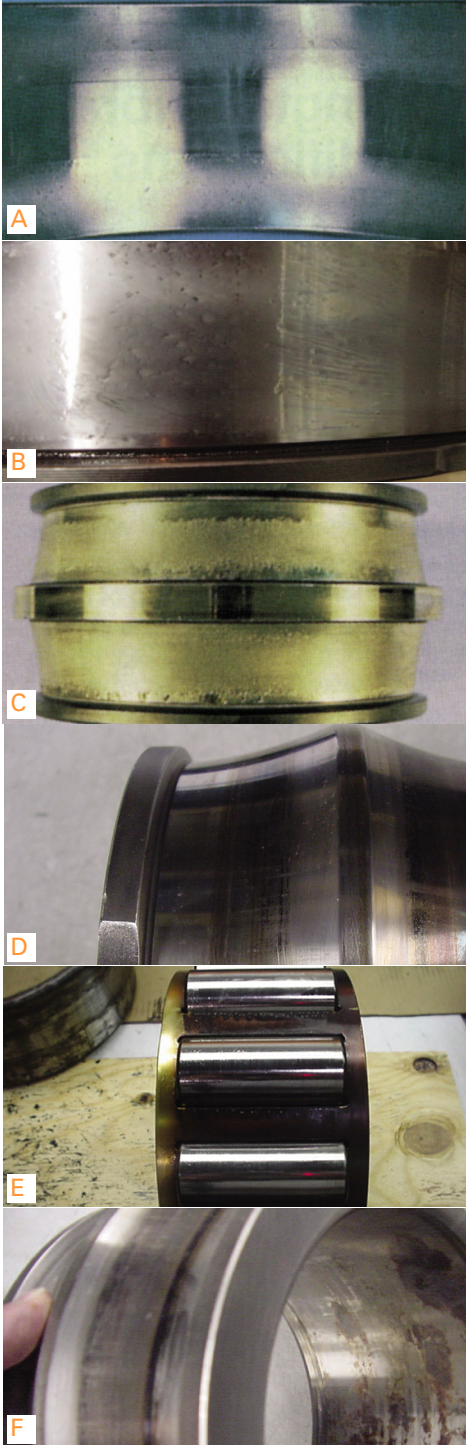

Figure 3:
Common bearing damage modes

Bearing Fit on Shaft and in Housing

Proper fitting of roller bearings to shafts and in housings also is critical to performance. If the fit is too tight or too loose, problems including creep, excessive vibration and premature failure may occur. Recommended fit values should be re-visited each time crusher bearings are replaced or repaired. For instance, a shaft that has been reused repeatedly can be slightly smaller than the day the machine was commissioned. An undersized shaft – even at extremely small scales – can cause improper bearing fit and cause premature bearing failure. Also, over time, bearing housings can get worn or become out of round. Both conditions can cause improper bearing support and premature failure. If concerns about proper shaft and housing dimensions arise, operators should consult an expert to evaluate the proper bearing shaft and housing fits.

Damage Analysis

Upon replacement, thorough bearing inspection can uncover issues with the shaft or housing fits, lubrication or re-lubrication activity, or contamination from poor sealing. Conducting an in-depth bearing inspection and determining the failure mode provides the opportunity to address the root cause of the bearing failure, helping to improve bearing performance with a replacement.

Crusher bearing damage often relates to contamination, improper lubrication and fretting (metal-to-metal wear). Here's how to identify common modes:

- **Abrasive Wear** and **Debris Denting** are two of the most common damage modes caused by contamination. Typically, abrasive wear appears frosty gray (Fig. 3A). Debris particles also can dent the surface of the races and rollers (Fig. 3B), which can lead to spalling damage. Frequent re-lubrication helps to purge contamination from the bearing. Persistent contamination problems could be a sign of improper sealing.
- **Inadequate Lubrication** can be caused by improper viscosity, too little or too much lubricant, or lubricant breakdown. Inadequate lubrication can result in fine grain spalling (Fig. 3C), heat damage (Fig. 3D), and oxidized lubricant staining (Fig. 3E).
- **Fretting or Fretting Corrosion** normally affects the bore (Fig. 3F) or the outer diameter of a bearing. It typically results from a loose fit, leading to relative motion between the bearing and the shaft or housing. Corrosion that results from fretting should be removed from the bearing area because it is abrasive and will damage the bearings and seals. Using the proper shaft and housing fits should minimize the amount of fretting damage to the bearing.

Training

Often, problems with bearing performance stem from insufficient on-the-job training or repeated misinformation. Both bearing suppliers and OEMs often offer on-site learning and training opportunities. An annual refresher, including proper fitting and care, proper sealing and lubrication, can benefit even the most seasoned personnel. Given the demanding life of crushers, proper maintenance practices, including re-lubrication and a committed inspection schedule, can greatly extend the life of roller bearings and machine reliability.

Images: The Timken Company